

Crystalens 5.0

(Model AT-50SE)

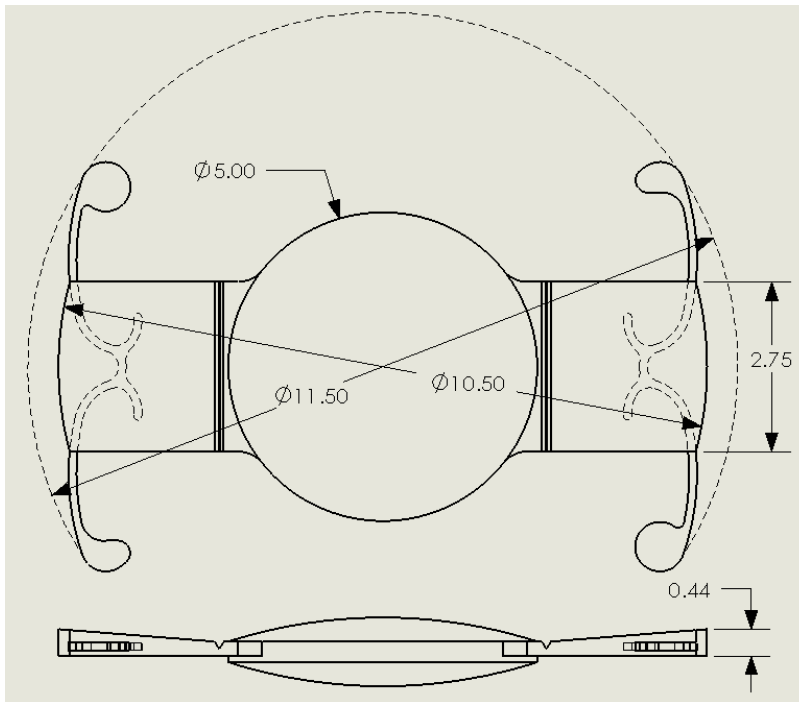

Refer to enclosed Physician Labeling.

The Staar MSI-TF or MSI--PF injector in conjunction with the Staar MTC-60c cartridge may be used to inject the lens. The lens should be injected within five minutes after loading. Refer to the instructions for use supplied with the injector. A cohesive viscoelastic should be used for lubrication of the injector when injecting the lens. See <http://www.crystalens.com> for a video detailing the use of the lens injector with the crystalens Five-0.

Dioptr power: +17 to +27 in 0.25 diopter increments and from +27 to +33 diopters in 0.5 diopter increments

Crystalens 5.0

(Model AT-52SE)

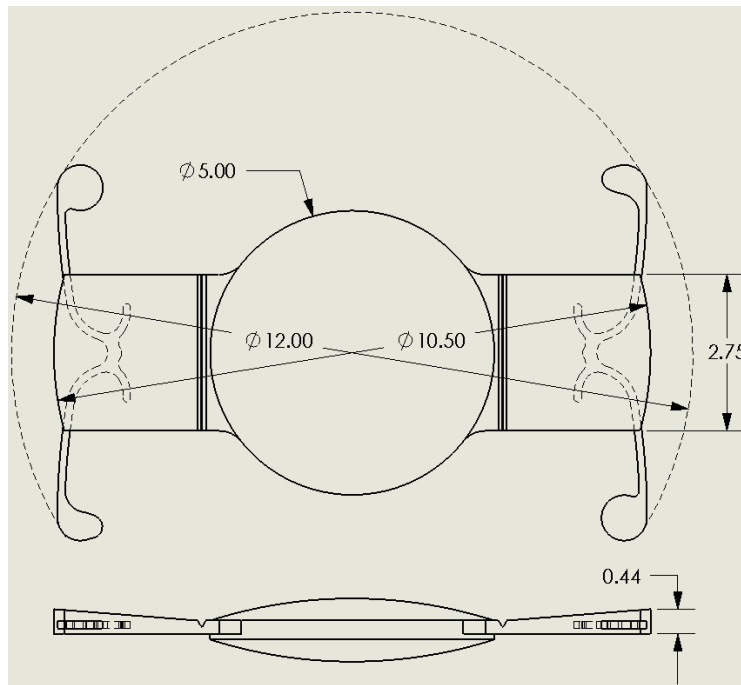

Refer to enclosed Physician Labeling.

The Staar MSI-TF or MSI--PF injector in conjunction with the Staar MTC-60c cartridge may be used to inject the lens. The lens should be injected within five minutes after loading. Refer to the instructions for use supplied with the injector. A cohesive viscoelastic should be used for lubrication of the injector when injecting the lens. See <http://www.crystalens.com> for a video detailing the use of the lens injector with the crystalens Five-0.

**Dioptr power: +4 to +10 in 1.0 diopter increments,
+10 to +16 in 0.5 diopter increments and
from +16 to +16.75 diopters in 0.25 diopter increments**



PHYSICIAN LABELING

Rx only

Device Description

The eyeonics™ crystalens SE™ Accommodating Posterior Chamber Intraocular Lens is a modified plate haptic lens with hinges across the plates adjacent to the optic.

Indications for Use

The crystalens SE™ is intended for primary implantation in the capsular bag of the eye for the visual correction of aphakia secondary to the removal of a cataractous lens in adult patients with and without presbyopia. The crystalens SE™ provides approximately one diopter of monocular accommodation which allows for near, intermediate, and distance vision without spectacles.

Warnings

1. Some patients may still require glasses to perform certain tasks.
2. There is no clinical data to support placing this lens in the ciliary sulcus.
3. The safety and effectiveness of this lens have not been evaluated in patients under 50 years of age.
4. The effect of vitrectomy on accommodation is unknown.
5. Small amounts of lens decentration occurring with an IOL having a narrow or small optic (< 5.5 mm) may cause glare or other visual disturbances under certain lighting conditions. Surgeons should consider this potential complication before implanting an IOL with a small or narrow optic. This lens incorporates a 4.5 mm optic, the smallest IOL optic diameter currently available in the U.S.
6. YAG-laser posterior capsulotomies should be delayed until at least 12 weeks after the implant surgery. The posterior capsulotomy opening should be limited to no more than 4 mm. Consistent with other IOLs, there is an increased risk of lens dislocation and/or secondary surgical re-intervention with early or large YAG capsulotomies.

7. The crystalens SE™ should not be implanted if the capsular bag is not intact or if there is any zonular rupture.
8. The safety and effectiveness of the device has not been established in patients with the following ocular conditions:
 - a. chronic drug miosis
 - b. Amblyopia
 - c. diabetic retinopathy
 - d. previous corneal transplant
 - e. history of retinal detachment
 - f. congenital bilateral cataracts
 - g. Recurrent anterior or posterior segment inflammation of unknown etiology, or any disease producing an inflammatory reaction in the eye.
 - h. Patients in whom the intraocular lens may interfere with the ability to observe, diagnose or treat posterior segment diseases.
 - i. Surgical difficulties at the time of intraocular lens implantation which might increase the potential for complications (e.g., persistent bleeding, significant vitreous prolapse or loss).
 - j. Corneal endothelial dystrophy.
 - k. Pseudoexfoliation syndrome.
 - l. Suspected microbial infection.
9. Surgeons considering lens implantation in such patients should explore the potential risk/benefit ratio.
10. Mechanical hinge testing has been evaluated in a laboratory setting. Hinge movements of 1,000,000 cycles at 10 cycles per second have been documented with no degradation of hinge integrity or stability. However, long-term stability in the human eye has not been established. Therefore, surgeons should continue to monitor implant patients postoperatively on a regular basis.
11. The effectiveness of ultraviolet light absorbing lenses in reducing the incidence of retinal disorders has not been established. This lens does not significantly absorb light in the ultraviolet region. Patients should be informed that they should wear sunglasses with UV400 protection when in sunlight.
12. The rate of cystoid macular edema may increase with sulcus-bag placement of the haptics.

Precautions

1. Do not resterilize this intraocular lens by any method (See Returned Lens Policy).
2. Do not store lenses at temperatures over 45°C (113°F).
3. Do not implant this lens in the anterior chamber.
4. The crystalens SE™ will center automatically at the end of surgery. The optic should be vaulted backward to a position corresponding to the normal location of the posterior capsule. Attempts to position the lens further posteriorly by hyper-inflating the globe with BSS could lead to hyperopic outcomes and should be avoided.

5. A wound leak could cause forward vaulting of the optic. Therefore a scleral tunnel or long multiplane limbal/corneal incision is recommended with a long narrow paracentesis. These incisions are less likely to require suturing, which could cause astigmatism and reduce the postoperative uncorrected vision.

Adverse Events

The incidence of adverse events experienced during the clinical trial was comparable to or lower than the incidence reported in the historic control (“FDA grid”) population (see Table 12). As with any surgical procedure, risk is involved. Potential adverse events accompanying cataract or implant surgery may include, but are not limited to, the following: lens subluxation, corneal endothelial damage, non-pigment precipitates, cystoid macular edema, infection, retinal detachment, vitreous loss, pupillary block, secondary glaucoma, iris prolapse, vitreous-wick syndrome, uveitis, and pupillary membrane.

Clinical Trial

The US clinical trial of the crystalens™ Model AT-45 was conducted in 497 eyes of 324 patients. The range of axial lengths studied in the clinical trial of the crystalens™ was 21.0 to 26.6 mm and the dioptric power range was 16.5 to 27.5 D. The clinical results were obtained using an ‘A’ Constant of 119.0, the SRK/T formula, immersion biometry or interferometry and manual keratometry.

Results

The results achieved by 304 patients followed for one year provide the data that were used to support the conclusion that postoperatively, the majority of patients implanted with this lens achieve excellent near, intermediate, and distance vision without spectacles. Visual acuity with or without correction at all distances improves when both eyes are implanted with a crystalens™.

1. In 124 bilaterally-implanted patients, the proportion of patients achieving uncorrected visual acuities of 20/32 (J2) or better at one year was:			
□ Distance	97.6%		
□ Intermediate	100%	at 80 cm	
□ Near	93.5%	at 40 cm	
2. In the 74 bilaterally-implanted patients who were within ±0.5 D of plano in each eye, the proportion of patients achieving uncorrected visual acuities of 20/32 (J2) or better at one year was:			
□ Distance	100%		
□ Intermediate	100%	at 80 cm	
□ Near	97.3%	at 40 cm	

The visual acuity and patient survey results are presented in Tables 2-11.

The stability of the outcomes was demonstrated in a consistent cohort of patients across the Form 3 to Form 4 (1-2 months to 3-6 months) and Form 4 to Form 5 (3-6 months to 11-15- months) postoperative intervals. Stability was measured using both the manifest spherical equivalent (MRSE) and visual acuity.

In a substudy comparing the crystalens™ with a control population comprised of several models of standard IOLs of varying types (e.g., single piece, multipiece) and materials (e.g., silicone, acrylic), the visual acuity at all distances at 3-6 months postoperative was significantly greater in crystalens™ implanted eyes than in eyes implanted with a standard IOL. The results are shown in Table 1.

Detailed Device Description

Lens Optic

- Material: Silicone Elastomer (Biosil™)
- Light transmittance: 95% ($\pm 5\%$) in the visible region of the light spectrum (425-750 nm). UV cut-offs at 10% T for a +4 diopter lens (thinnest) and a +34 diopter lens (thickest) occurs at 350-355 nm as shown in Figure 1
- Index of refraction: 1.428 (35°C)

Please refer to the addendum supplied with each lens model for more detailed information on the specific lens model.

Haptics

The plate haptics have hinges across the face of the plates adjacent to the optic. Two flexible colored polyimide (Kapton™) loops are attached to each distal extremity of the plates, making the lens 11.5 mm in overall length. The length of the plate is 10.5 mm.

Mechanism of action

The crystalens SE™ was designed to move in a backward and forward motion along the axis of the eye in response to pressure changes in the vitreous cavity and anterior chamber that result from relaxation and contraction of the ciliary muscle. The exact mechanism of action has not been fully elucidated.

Directions for Use

1. Prior to implanting, examine the lens package for IOL type, power, and expiration date.
2. Open the peel pouch and remove the lens from the sterile packaging by pressing and lifting the cover off the plastic lens case (holder). Place the lens in a sterile environment.
3. Examine the lens thoroughly to ensure particles have not become attached to it, and examine the lens optical surface for other defects.

4. Position the lower blade of the forceps in the slot of the lens case beneath the lens. A Cumming intraocular lens forceps is recommended. Grasp the lens so that the forceps extends across the *distal hinge* to stabilize the *leading plate haptic*. Do not grasp the lens by the haptics.
5. Remove the lens in its position for implantation with a single grasp.
6. Advance the forceps to place the *leading plate haptic* of the lens into the distal capsular bag, which should be completely filled with a cohesive viscoelastic.
7. The round knob on the loop of the leading haptic should be on the right to ensure that the hinge's "open" side is "right side up" and is facing the anterior part of the eye on implantation.
8. With a second instrument, hold the proximal *polyimide loop* to maintain the position of the lens in the capsular bag as the implantation forceps are withdrawn from the eye.
9. Regrasp at the tip of the *trailing plate haptic* with the implantation forceps.
10. As you advance the *trailing plate haptic* into the anterior chamber, the *polyimide loops* will bend back on themselves as they traverse the small incision. Advance the leading plate up towards the cornea. *This will cause the leading plate haptic to bend to a right angle deep into the bag.*
11. Maintain your grasp at the tip of the *trailing plate haptic*. Tuck the polyimide loops, one by one, into the capsular bag. Do not release the tip until the loops are in the bag.
12. Release and withdraw the forceps. The lens will self-center.
13. Please refer to the addendum supplied with each lens model for more detailed information on the use of injectors with the crystalens.

NOTE: The lens may pick up an electrostatic charge upon opening the package. The lens should be carefully examined to ensure that particles have not been attracted to its surface.

Lens Power Calculations

The surgeon should determine preoperatively the power of the lens to be implanted by using either immersion or IOL Master biometry and manual keratometry. Lens power calculation methods are described in the following references:

- Holladay JT et al. A Three Part System for Refining Intraocular Lens Power Calculations. J Cataract Surg 14, January 1988.
- Retzlaff JA et al. Development of the SRK/T intraocular lens implant power calculation formula. J Cataract Refract Surg 16, May 1990.
- Hoffer KJ. The Hoffer Q Formula. A comparison of theoretical and regression formulas. J Cataract Refract Surg 19, November 1993.

NOTE: The Surgeon Factor, 'A' Constant and ACD values, which are located on the outside of the package, are estimates only. It is recommended that the surgeon determine his/her own values based on their individual clinical experience. Surgeons requiring additional information on lens power calculation may contact eyeonics.

Recommendations for Maximizing Patient Outcomes

- Manual keratometry, immersion biometry or interferometry is strongly recommended to obtain optimum patient outcomes.
- The first eye implant should be targeted for between -0.25 and -0.50 diopter and the second eye implant targeted for plano. In any case, the outcome of the second eye implant should be determined based on the outcome of the first eye.
- A waiting period of two weeks between the first and second eye is recommended in order to accurately determine the lens power for the second eye .
- Incision width should be 3.5 to 3.7 mm but no larger than 4 mm and should be at least 2.5 mm long. The paracentesis should be approximately 1.0 to 1.5 mm in width and approximately 2.0 mm long.
- The capsulorhexis should be round (5.5 to 6.0 mm) with the anterior capsule covering the plate haptics. If the capsulorhexis is oval, then the lens should be rotated to ensure maximum coverage of the plate haptics.
- Meticulous cortical clean-up should be performed and the lens rotated at least 90° to dislodge any hidden or trapped cortex.
- Patients should be kept on a tapering course of anti-inflammatory agents for a minimum of 4 weeks.

Patient Registration Instructions and Reporting Registration

Each patient who receives a crystalens SE™ must be registered with eyeonics™ at the time of lens implantation.

Registration is accomplished by completing the Implant Registration Card that is enclosed in the lens package and mailing it to eyeonics™. Patient registration is essential and will assist eyeonics™ in responding to adverse reaction reports and/or potentially sight-threatening complications. An implant identification card is supplied in the lens package and must be given to the patient.

Reporting

Adverse Reactions and/or potentially sight-threatening complications that may reasonably be regarded as lens related and that were not previously expected in nature, severity or degree of incidence should be reported to eyeonics™ at 866-eyeonics (393-6642) (USA). This information is being requested from all surgeons in order to document potential long-term effects of intraocular lens implantation.

How Supplied

The contents of the inner and outer peel pouches are sterile unless the packages are damaged or opened. The intraocular lenses are moist heat sterilized and supplied in a lens case within a double aseptic transfer peel pouch. The contents of the inner and outer peel pouches are sterile unless the packages are damaged or opened.

Expiration Date

Sterility is guaranteed unless the sterile pouch is damaged or opened. In addition, there is a sterility expiration date that is clearly indicated on the outside of the package. The lens should not be used after the indicated date.

Returned Lens Policy

Please contact your local eyeonics™ office regarding lens exchange.

Bibliography

1. Boettner, EA and Wolter JR 1962. Transmission of the ocular media. *Invest Ophthalmol* 1: 776-783.
2. Busacca, A. La Physiologie Du Muscle Ciliaire Etudiee Par La Gonioscopie. *Annales D'Oculistique* 1955; 1-21.
3. Coleman J. On the hydraulic suspension theory of accommodation. *Trans Am Ophth Soc* 1986; 846-868.
4. Colin, J. Clinical results of implanting a silicone haptic-anchor-plate intraocular lens. *J Cataract Refract Surg*, 1996;2:1286-1290.
5. Cumming JS et al. Clinical evaluation of the Model AT-45 silicone accommodating intraocular lens. *Ophthalmology* 2001;108:2005-2010.
6. Cumming JS, Ritter J. The Measurement of Vitreous Cavity Length and its Comparison Pre- and Postoperatively. *Eur J Implant Ref Surg* 1994;6:261-272.
7. Fisher R. The ciliary body in accommodation. *Tran Ophthalmol Soc UK* 1986;105:208-219.
8. Girard LJ et al. Complications of the Simcoe Flexible Loop Phacoprosthesis in the anterior chamber. *Ophthalmic Surg* 14(4)
9. Glasser A and Kaufman PL. The mechanism of accommodation in primates. *Ophthalmol* 1999;106: 863-872.
10. Kammann J. Vitreous-stabilizing, single-piece, mini-loop, plate-haptic silicone intraocular lens. *J Cataract Refract Surg* 1998;24:98-106.
11. Thornton S. Accommodation in pseudophakia. *Color Atlas of Lens Implantation*. 1991;159-162.
12. Willis DA, Stewart RH, Kimbrough RL. Pupillary block associated with posterior chamber lenses. *Ophthalmic Surg* 1985; 16:108-9.

Table 1
crystalens™ vs Standard IOL Visual Acuity
(Best Spectacle Corrected Distance and Near and Intermediate Acuity
Through the Distance Correction)

	Crystalens™		Standard IOL	
20/20 or better	1/121	0.8%	0/64	0.0%
20/25 or better	29/121	24.0%	0/64	0.0%
20/32 or better	61/121	50.4%	3/64	4.7%
20/40 or better	107/121	88.4%	23/64	35.9%
Worse than 20/40	14/121	11.6%	41/64	64.1%

Table 2
Bilateral – Uncorrected Visual Acuity

	Near at 40 cm		Intermediate at 80 cm		Distance	
20/20 or better	39/124	31.5%	120/124	96.8%	98/123	79.7%
20/25 or better	90/124	72.6%	122/124	98.4%	113/123	91.9%
20/32 or better	116/124	93.5%	124/124	100%	120/123	97.6%
20/40 or better	122/124	98.4%	124/124	100%	121/123	98.4%
Worse than 20/40	2/124	1.6%	0/124	0%	2/123	1.6%

Table 3
Bilateral – Uncorrected Visual Acuity for Patients Within ±0.5D of Plano in Each
Eye

	Near at 40 cm		Intermediate at 80 cm		Distance	
20/20 or better	17/74	23.0%	NA	NA	67/74	90.5%
20/25 or better	49/74	66.2%	74/74	100%	73/74	98.6%
20/32 or better	72/74	97.3%	74/74	100%	74/74	100%
20/40 or better	74/74	100%	74/74	100%	74/74	100%
Worse than 20/40	0/74	0%	0/74	0%	0/74	0%

**Table 4
Bilateral Uncorrected Visual Acuity (1 Year Versus 3 Year)**

	Near at 40 cm				Distance			
	1 Year		3 Year		1 Year		3 Year	
20/25 or better	90/124	72.6%	36/50	72.0 %	113/123	91.9%	46/50	92.0%
20/32 or better	116/124	93.5%	43/50	86.0 %	120/123	97.6%	47/50	94.0%
20/40 or better	122/124	98.4%	49/50	98.0 %	121/123	98.4%	49/50	98.0%
Worse than 20/40	2/124	1.6%	1/50	2.0%	2/123	1.6%	1/50	2.0%

**Table 5
Bilateral Distance Corrected Near Visual Acuity (1 Year Versus 3 Year)**

	1 Year		3 Year	
20/25 or better	64/124	51.6%	29/50	58.0%
20/32 or better	104/124	83.9%	42/50	84.0%
20/40 or better	124/124	100%	50/50	100%
Worse than 20/40	0/124	0%	0/50	0%

**Table 6
Unilateral - Uncorrected Visual Acuity (All Eyes)**

	Near at 40 cm		Intermediate at 80 cm		Distance	
	20/20 or better	52/368	14.1%	--	--	184/371
20/25 or better	161/368	43.8%	--	--	269/371	72.5%
20/32 or better	256/368	69.6%	--	--	311/371	83.8%
20/40 or better	328/368	89.1%	--	--	339/371	91.4%
Worse than 20/40	40/368	10.9%	--	--	32/371	8.6%

Table 7
Bilateral Patient Survey*
Activities Without Spectacles
US Bilateral Subjects

Activity	Yes N/N (%)	No n/N (%)
Perform most visual functions	120/128 (93.8%)	8/128 (6.3%)
Read most things	100/129 (77.5%)	29/129 (22.5%)
Go shopping	116/124 (93.5%)	8/124 (6.5%)
Participate in sports	84/87 (96.6%)	3/87 (3.4%)
Attend social gatherings	120/126 (95.2%)	6/126 (4.8%)
Drive	111/121 (91.7%)	10/121 (8.3%)
Read a newspaper	73/128 (57.0%)	55/128 (43.0%)
Sew or do needlework	35/91 (38.5%)	56/91 (61.5%)
Work on a computer	75/93 (80.6%)	18/93 (19.4%)
Do handy work around the house	119/126 (94.4%)	7/126 (5.6%)
Walk	126/129 (97.7%)	3/129 (2.3%)
Shop	117/128 (91.4%)	11/128 (8.6%)
Watch television	120/130 (92.3%)	10/130 (7.7%)

*Self-administered anonymous mail-in survey

Table 8
Bilateral Patient Survey
Difficulty With Night Activity
US Bilateral Subjects

Symptoms	Absent N/N (%)	Mild N/N (%)	Moderate n/N (%)	Severe n/N (%)
Night-time glare/flare	74/130 (56.9%)	31/130 (23.8%)	18/130 (13.8%)	7/130 (5.4%)
Night vision (difficulty driving at night)	82/121 (67.8%)	21/121 (17.4%)	14/121 (11.6%)	4/121 (3.3%)
Halos (rings around lights)	80/130 (61.5%)	26/130 (20.0%)	16/130 (12.3%)	8/130 (6.2%)

Table 9
Bilateral Patient Survey
Wearing Spectacles During Waking Hours And to See At Night
US Bilateral Subjects

Wearing Spectacles	n/N (%)
How often do you wear spectacles during waking hours?	
I do not wear spectacles	33/128 (25.8%)
I wear spectacles almost none of the time (10%-25%)	61/128 (47.7%)
I wear spectacles some of the time (26%-50%)	20/128 (15.6%)
I wear spectacles most of the time (51%-75%)	8/128 (6.3%)
I wear spectacles all the time or almost all the time (76%-100%)	6/128 (4.7%)
Do you wear spectacles to see at night?	
No	110/130 (84.6%)
Yes	20/130 (15.4%)

Table 10
Adverse Events Reported at 12 months

Adverse Event	Cumulative		FDA Grid	Persistent		FDA Grid
	Primary Eyes	All Eyes		Primary Eyes	All Eyes	
Endophthalmitis	1/324 (0.3%)	1/497 (0.2%)	0.1%	----	----	----
HypHEMA	1/324 (0.3%)	1/497 (0.2%)	2.2%	----	----	----
Hypopyon	0/324	0/497	0.3%	----	----	----
IOL Dislocation	0/324	0/497	0.1%	----	----	----
Cystoid Macular Edema	12/324 (3.7%)	13/497 (2.6%)	3.0%	2/304 (0.7%)	3/450 (0.7%)	0.5%
Pupillary Block	0/324	0/497	0.1%	----	----	----
Retinal Detachment	0/324	0/497	0.3%	----	----	----
Secondary Surgical Reintervention	2/324 (0.6%)	4/497 (0.8%)	0.8%	----	----	----
Corneal Edema	----	----		0/298	0/440	0.3%
Iritis	----	----		2/298 (0.7%)	3/440 (0.7%)	0.3%
Raised IOP Requiring Treatment	----	----		0/304	0/450	0.4%

Figure 1

**SPECTRAL TRANSMITTANCE
(PERCENTAGE OF UV/VIS TRANSMITTED)**

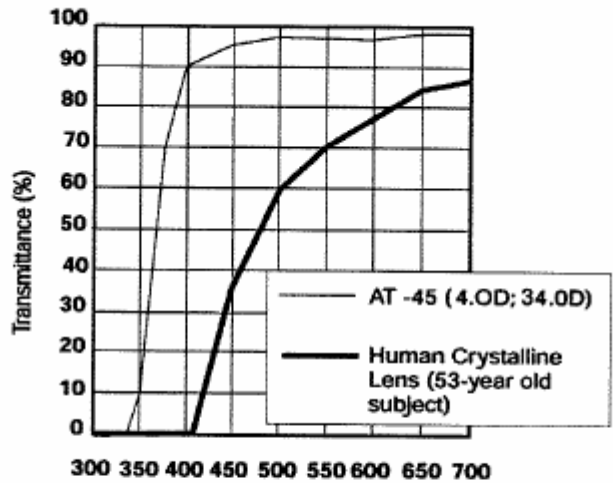

Legend
Curve 1:

Spectral Transmittance (T) Curve Corresponding to the Central Region of the thinnest lens (+4 Diopter IOL). 10% UV cut-off is 350-355 nm.
Spectral Transmittance (T) Curve Corresponding to the Central Region of the thickest lens (+34 Diopter IOL). 10% UV cut-off is 350-355 nm.

Curve 2: Spectral Transmittance (T) Curve* Corresponding to a 53 year-old Phakic Eye.

Note: The spectral transmittance curves represent the range of transmittance values of IOLs made with this material.

* Bibliography reference #1

SYMBOL	ENGLISH
	MANUFACTURE DATE (MM-YY: month-year)
	DO NOT REUSE
	USE BY (MM-YY: month-year)
	SEE INSTRUCTIONS FOR USE
	STERILIZED BY STEAM

Manufactured in the USA by eyeonics inc., Aliso Viejo, CA 92656 USA (866) 393-6642